



Grille Guard

Part No. E0003S/B



Fits: **2005-2015**

Toyota Tacoma



Incl. Eco Boost
THE GRILLE GUARD MAY INTERFERE WITH PARKING SENSORS,
PROXIMITY SENSORS AND CRUISE CONTROL SENSORS.



REMOVE CONTENTS FROM BOX. VERIFY ALL PARTS ARE PRESENT.



READ INSTRUCTIONS CAREFULLY BEFORE STARTING INSTALLATION.

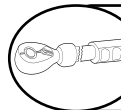

DO NOT OVER TORQUE. STANDARD OPERATING LOAD FOR TIGHTEN
BODY MOUNT NUTS & BOLTS VARIES FROM 45 TO 65 FOOT POUND.



60-180 min



Cutting Not
Required



Drilling Not
Required



support@trailfx.com



1 866 638 4870



POLISHED STAINLESS STEEL – LIMITED LIFETIME
POWDER COATED BLACK – 3 YEARS

PARTS LIST:

Qty	Part Description	Qty	Part Description
1	Grille Guard	6	12-1.75mm x 35mm Hex Bolts
1	Driver/Left Mounting Bracket	16	12mm x 32mm OD x 3mm Flat Washers
1	Passenger/Right Mounting Bracket	8	12mm Nylon Lock Nut
1	Driver/Left Top Bracket	2	10-1.5mm x 30mm Button Head Bolts
1	Passenger/Right Top Bracket	4	10mm x 27mm OD x 3mm Large Flat Washers
2	10-1.50mm x 30mm "T" Bolts	4	10mm Nylon Lock Nuts
2	12-1.75mm x 120mm Hex Bolts		

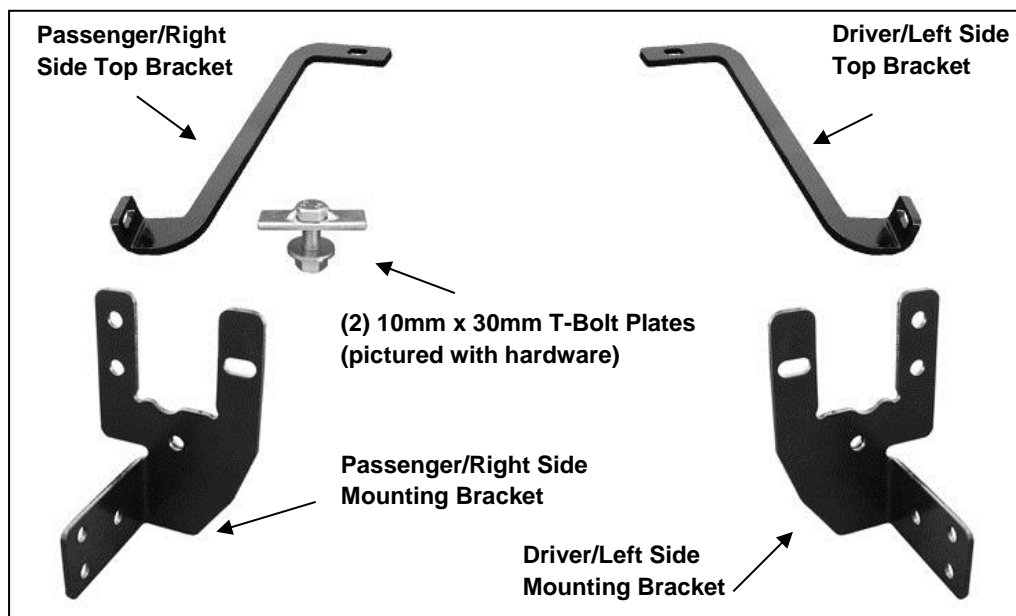

INSTALLATION PROCEDURE:

- 1. REMOVE CONTENTS FROM BOX. VERIFY ALL PARTS ARE PRESENT. READ INSTRUCTIONS CAREFULLY BEFORE STARTING INSTALLATION. DO NOT ATTEMPT INSTALLATION ALONE; PERSONAL INJURY OR DAMAGE TO THE TRUCK MAY RESULT.**
2. Starting on the driver side, remove the (3) factory nuts bolting the bumper support to the end of the frame channel, **(Figures 1 - 3)**.
3. Line-up the (3) upper holes in the driver side Frame Mounting Bracket with the threaded studs in the end of the frame channel. Bolt the Bracket to the studs using the existing nuts removed in **Step 2, (Figures 1 - 3)**. Insert (1) 12mm x 120mm Hex Bolt with (1) 12mm Flat Washer through the lower mounting hole in the bracket and into the end of the frame channel. Use the included (1) 12mm Flat Washer and (1) 12mm Nylon Lock Nut to secure the Bracket to the lower mounting hole, **(Figure 1 & 3)**. Tighten hardware at this time.
4. Repeat **Steps 2 - 3** for passenger side Frame Mounting Bracket installation.
5. Open the hood on the vehicle. Locate the factory hole on each side of the bottom of the radiator support cross member behind the grille insert, **(passenger side pictured-Figure 4)**. Select (1) 10mm Bolt Plate. Insert the Bolt Plate through the back of the crossmember and down through the hole in the bottom of the cross member, **(Figures 4 - 7)**.
6. Slide the driver side Top Bracket through the plastic grille opening and attach it to the previously inserted Bolt Plate using the included (1) 10mm Flat Washer and (1) 10mm Nylon Lock Nut, **(Figure 5)**. Do not tighten hardware. Repeat this Step for remaining Top Bracket installation, **(Figure 6)**.
7. With assistance, position the Grille Guard onto the inside of the Mounting Brackets. Use the included (6) 12mm x 35mm Hex Bolts, (12) 12mm Flat Washers and (6) 12mm Nylon Lock Nuts to attach the Grille Guard to the Mounting Brackets, **(Figures 2 & 3)**.
8. Line up the mounting hole in the passenger side Top Bracket with the corresponding hole in the upright on the Grille Guard. Bolt the Top Bracket to the Grille Guard with the included 10mm x 30mm Button Head Bolt, (1) 10mm Flat Washer and 10mm Nylon Lock Nut, **(Figure 7)**. Do not tighten hardware at this time. Repeat this Step to bolt the driver side Top Bracket to the Grille Guard.
9. Align the Grille Guard properly and tighten all hardware.
10. Do periodic inspections to the installation to make sure that all hardware is secure and tight.

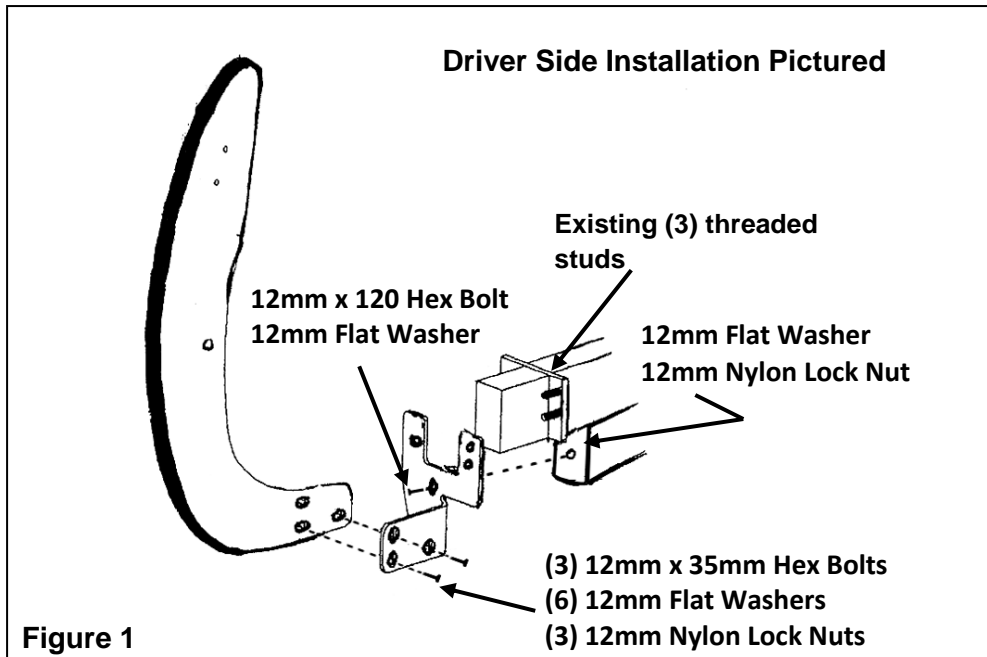

Factory hex nuts bolting driver side Frame Bracket to end of frame channel

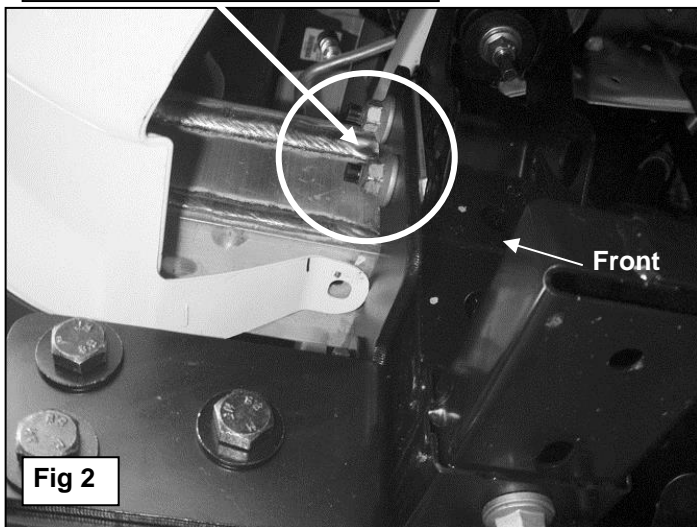

(3) 12mm x 35mm Hex Bolts
(6) 12mm Flat Washers
(3) 12mm Nylon Lock Nuts

12mm x 120mm Hex Bolt
(2) 12mm Flat Washers
12mm Nylon Lock Nut

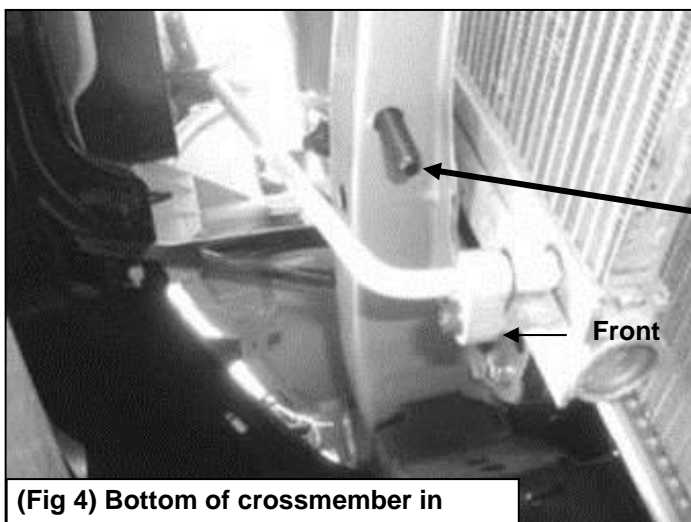

Insert T-Bolt Plate from behind and through hole in bottom of crossmember

NOTE: It is not necessary but it may be easier to bolt the Top Brackets to the horizontal crossmember in front of the radiator after the factory skid plate has been removed

10mm T-Bolt Plate
10mm Flat Washer
10mm x 27mm Large Flat Washer
10mm Nylon Lock Nut

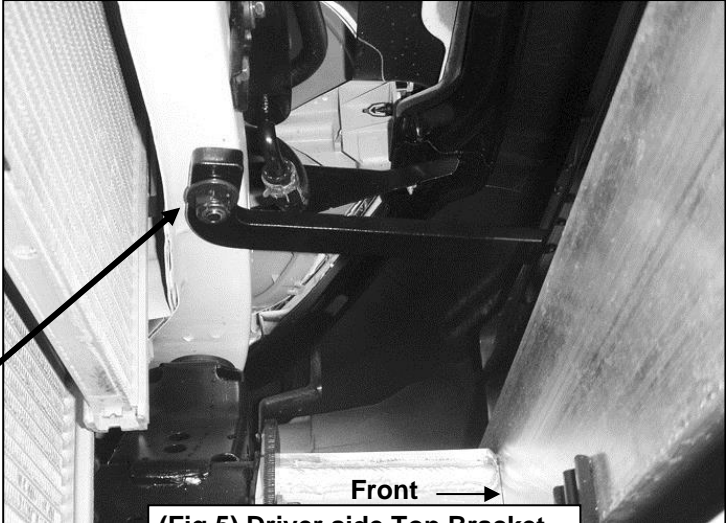

(Fig 5) Driver side Top Bracket installation pictured from below

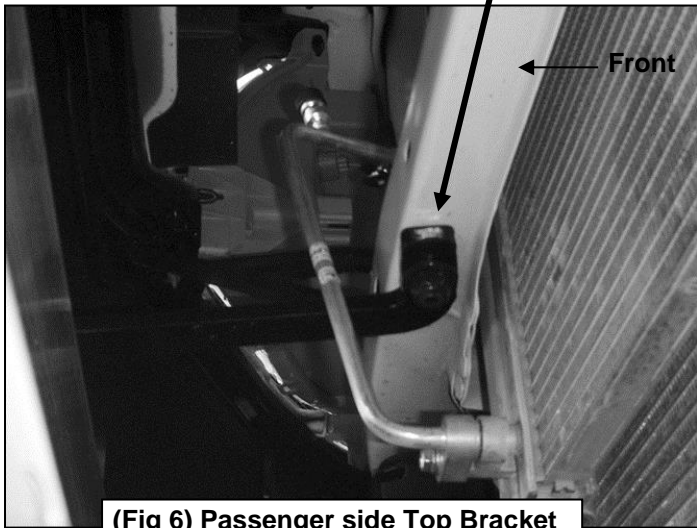

(Fig 6) Passenger side Top Bracket installation pictured from below

Bolt the Top Bracket to the Grille Guard with the included:
10mm x 30mm Button Head Bolt
10mm Flat Washer
10mm Nylon Lock Nut

T-Bolt Plate w/hardware

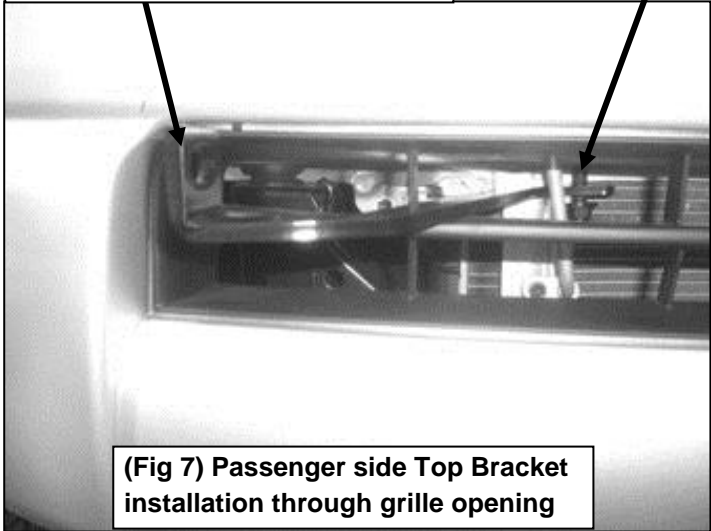

(Fig 7) Passenger side Top Bracket installation through grille opening



Complete Installation

PRODUCT CARE

- Periodically check the product to ensure all fasteners are tight and components are intact.
- Regular waxing is recommended to protect the finish of the product.
- **Use ONLY Non-Abrasive automotive wax.** Use of any soap, polish or wax that contains an abrasive is detrimental and can scratch the finish leading to corrosion.
- Aluminum polish may be used to polish small scratches and scuffs for **Stainless Steel finish.**
- Mild soap may be used to clean the product for both **Stainless Steel and Black finish.**

FAQ's**1. Hardware's are not of correct size.**

In GMC / Chevrolet truck model 2006 & up, customer needs to reuse the factory body bolts to install the bracket. If your vehicle is not GMC / Chevrolet 2006 & up, ensure that holes are not partially covered with any plastic grommet or rust? If it is, remove the plastic grommet & rust from the thread holes & re-try the installation.

2. Mounting Bracket are not getting Installed properly.

In some cases Illustration images shown in Installation manual may not be the exactly same as per actual vehicle images ,also if Driver / Passenger side mounting brackets are very identical in the design, suggest referring Parts Identification guide to avoid fitment issue.

3. Products are thumping / rattling after installation.

Ensure that all required mounting brackets / hardware's are installed & tighten correctly. Suggest using white lithium / regular grease between the metal to metal contact surfaces.

4. Side Bar is not aligning with vehicle / Step Pads are not aligning with vehicle doors.

Side bar may be interchanged or mounting brackets are not installed at the correct position in the vehicle. Refer Parts identification guide.

5. Missing / Excess Hardware.

Recheck hardware count as per the part list.

6. Product not installing properly.

Ensure make model year, cab length and bed size of your vehicle is listed in the application. All installation steps are followed correctly.

Check out these other TrailFX Products!!

www.TrailFX.com



SIDE BAR



HEADACHE RACKS



RUNNING BOARDS



ROCKER GUARDS

Keystone Automotive Operations Inc. (KAO) warrants this product to be free of defects in material and workmanship at the time of purchase by the original retail consumer. KAO disclaims any other warranties, express or implied, including the warranty of fitness for a particular purpose or an intended use. If the product is found to be defective, KAO may replace or repair the product at our option, when the product is returned prepaid, with proof of purchase. Alteration to, improper installation, or misuse of this product voids the warranty. KAO's liability is limited to repair or replacement of products found to be defective, and specifically excludes liability for any incidental or consequential loss or damage.